

Millipore®

User Guide

Pellicon® Capsule
Pellicon® Capsule Stand

The life science business of Merck KGaA, Darmstadt,
Germany operates as MilliporeSigma in the U.S. and Canada.

MILLIPORE
SIGMA

Contents

- Introduction** 2
- Pellicon® Capsules** 3
 - Before Use 3
 - Unpacking 3
 - Installation Materials 5
 - Operation Mode..... 5
 - Device Installation..... 5
 - Manifold Installation 8
- Integrity Testing** 11
- Conditioning Flush**..... 12
- Product Processing**..... 13
 - Concentration 13
 - Diafiltration 14
 - Recovery 14
 - Waste Compliance 14
- Pellicon® Capsule Stand** 15
 - Installation 15
- Troubleshooting** 16

Introduction

Pellicon® capsules are a family of single-use tangential flow filters available in three linearly scalable device sizes: 0.1, 0.5 and 1.5 m², and as pre-assembled manifolds of multiple capsules connected via tubing assemblies to enable membrane area installations of 1, 3, 4.5, 6, 7.5 and 9 m². Manifoldd sizes 1, 3 and 4.5 m² are provided fully assembled with aseptic connectors. Sizes 6, 7.5 and 9 m² are achieved by aseptically connecting two manifold assemblies of 3 or 4.5 m² at the user site (refer to [Manifold Installation](#)).

Capsule Size (m ²)	Available Connection Type
Device	
0.1, 0.5	¾ in. Sanitary Flange or AseptiQuik® G Connector
1.5	AseptiQuik® G Connector
Manifold	
1, 3, 4.5	AseptiQuik® G Connector
6, 7.5, 9	AseptiQuik® L Connector

The capsules are self-contained and do not require a compression holder. Sizes 0.1, 0.5 and 1 m² may be clamped on a user-supplied fixture or mounted onto a Pellicon® capsule stand for support (refer to [Pellicon® Capsule Stand](#) for installation). Sizes 1.5 m² and above are provided with a self-standing feature.

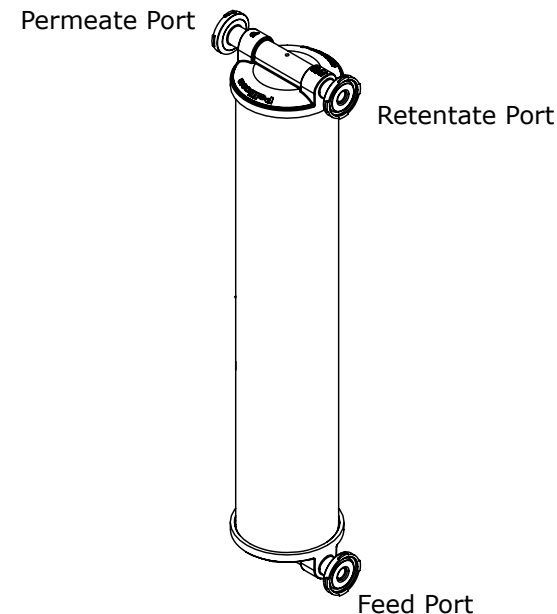

*Pellicon® capsule
(shown 0.5 m² with ¾ in. Sanitary Flange)*

Pellicon® Capsules

Before Use

Pellicon® capsules are wetted with preservative-free reverse osmosis water, double bagged, packaged and gamma sterilized. The radiation exposure label on the inner bag will be red to indicate gamma irradiation has been performed.

Store the product at ambient temperature and keep protective packing materials in place until installation. To prevent contamination, the capsule should be removed from the inner bag just prior to installation.

Visually inspect capsules to ensure no damage occurred during shipping. Pellicon® capsule manifolds should not be lifted or carried by the tubing assemblies.

Cleaning and sanitizing before use are not required.

Refer to the Certificate of Quality supplied in the box with each product for specifications.

Unpacking

Pellicon® capsules are individually packaged. The packaging includes double bags, foam pouches or foam frames, and a corrugated box. Pellicon® capsule manifolds in sizes 3 and 4.5 m² are palletized to provide additional protection during shipment.

CAUTION The 3 and 4.5 m² packages are heavy. Two people or a lifting aid may be required to move the package. Follow internal SOPs to ensure operator safety.

1. Cut sealing tape at the base on all four sides.

CAUTION Do not cut box open from top.

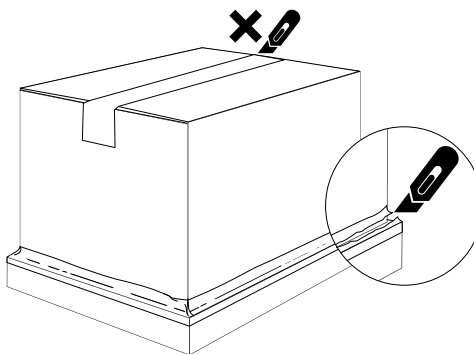

2. Lift and remove the top portion of the box.

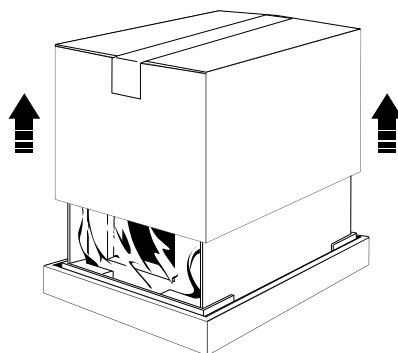

3. Using the handles, lift the assembly up and out of the bottom tray. Place the assembly on a stable surface.

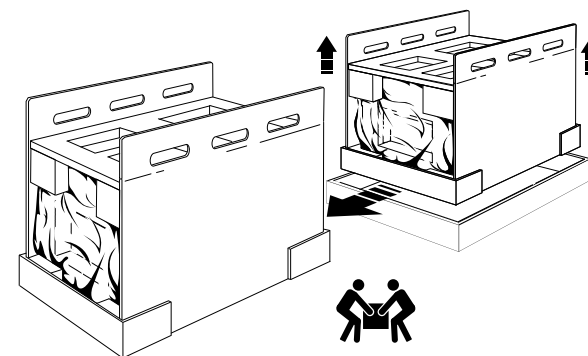

4. Lift and remove the top foam piece.

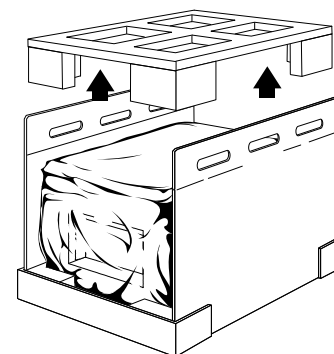

- Securely grasp the outer plastic bag assembly by its edges and lift free from the bottom foam piece and place on stable surface.

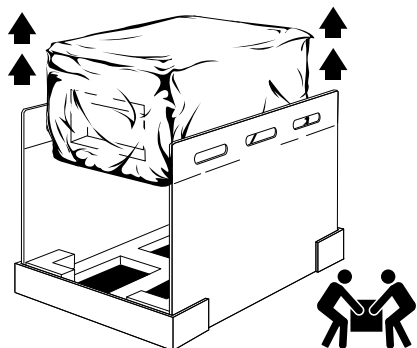

- Cut the outer bag at the seal and remove the inner-bagged manifold unit.

CAUTION

Do not cut open the inner bag until ready to use the product to prevent contamination.

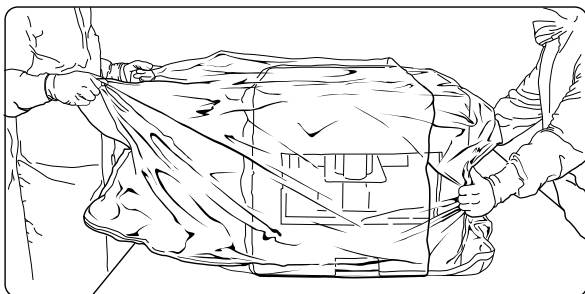

- Follow SOP prior to bringing it into a cleanroom.

- Place the bagged manifold on a flat surface, cut the inner bag at the seal and remove the foam assembly.

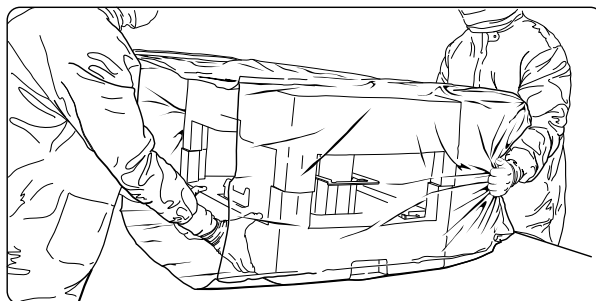

- Remove the top foam piece.

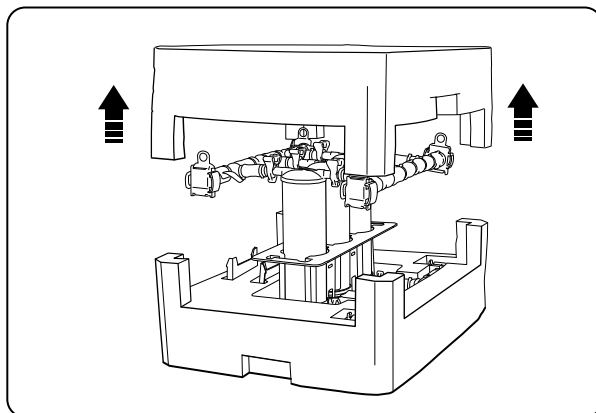

- Hold the bottom foam piece down and lift the manifold unit by the handles.

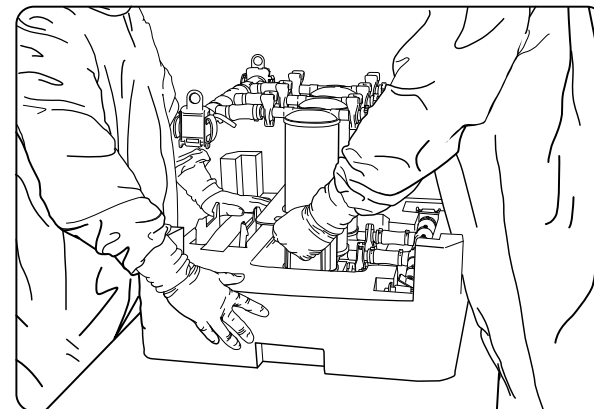

- For *E* manifolds only, pull the foam insert out to remove the center unification bracket.

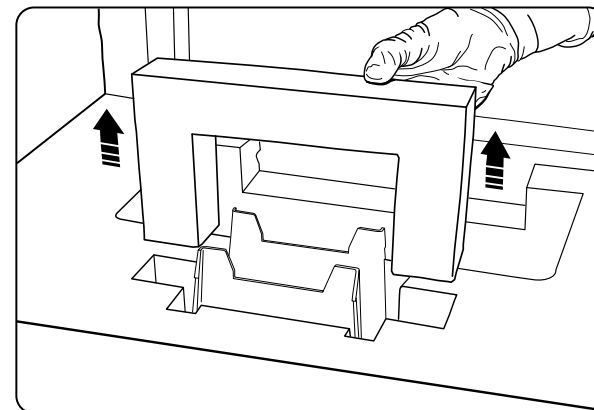

Once all packaging materials have been removed, the product is ready to use.

Installation Materials

Below is a list of recommended materials for Pellicon® capsule installation:

Component	Use
Diaphragm or Peristaltic Pump	Feed Pump, Permeate Pump (optional)
Diaphragm or Peristaltic Pump Head	Feed Pump Head, Permeate Pump Head (optional)
Sanitary Gaskets (included for capsules with AseptiQuik® Connectors)	Feed, Retentate, Permeate Ports
Sanitary Clamps (included for capsules with AseptiQuik® Connectors)	Feed, Retentate, Permeate Ports
Sanitary to Barb Fittings or hose barb AseptiQuik® Connectors	Feed, Retentate, Permeate Tubing Connections to Ports
Tubing	Feed, Retentate, Permeate, Recovery Lines
Pinch Clamps/Valves	Feed, Retentate, Permeate, Recovery Lines
Barb Tee	Recovery Line
Pressure Transducers	Feed, Retentate, Permeate Lines
Pressure Monitor	Pressure Sensor Monitor for Feed, Retentate, Permeate
Tank	Feed
Stirrer	Feed
Capsule Stand (sizes 0.1, 0.5 and 1 m ² only)	Capsule support

Use tubing compatible with solvents and pressures expected in the application.

The pump must have adequate capacity for the installation. The optimal feed flow rate will depend on the application and solution being filtered.

Operation Mode

Product installation and system setup is defined by the TFF operation mode:

Parameter	Operation Mode	
	Batch TFF	Single-pass TFF
Feed Flow Path	Recirculation	Pumped through the system once
Feed Flow Rate (L/min/m ²)	30 kDa: 4 to 8 100, 300 kDa: 4 to 6	≤ 1
Multiple Capsule Installation	Parallel	Series

Device Installation

Pellicon® capsule devices are supplied with port twist caps on sanitary flanges for sizes 0.1 and 0.5 m² only, or with AseptiQuik® G connectors for all three sizes. Capsules supplied with port caps require fractional sanitary fittings, gaskets, and clamps to connect the tubing to the capsule feed, retentate and permeate ports.

Capsules supplied with AseptiQuik® G connectors are provided pre-assembled with sanitary gaskets and clamps, and require user supplied AseptiQuik® G connector halves to connect the system flowpath to the capsule feed, retentate and permeate ports.

During installation and use, avoid stress such as impact, pulling or stretching at connection points.

Batch TFF Installation

Batch TFF installations allow the feed to pass through the filter assembly multiple times. If installing multiple devices, assemble for parallel flow using tubing to connect shared feed, retentate, and permeate lines.

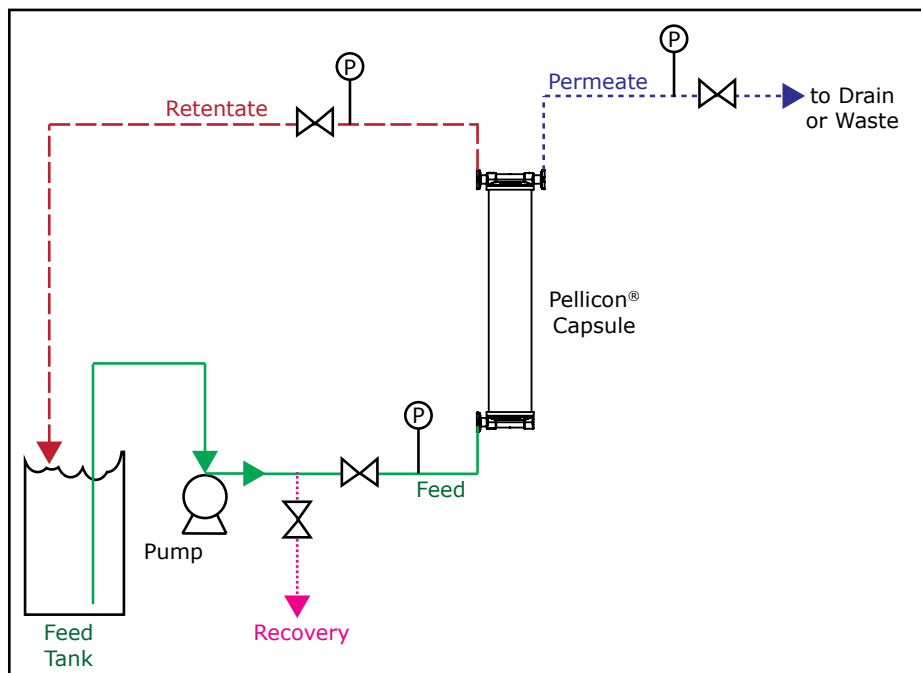

Batch TFF installation with one Pellicon® capsule

1. Install the Pellicon® capsule(s) vertically with the permeate and retentate ports on top.
2. **Capsules supplied with port caps:** Remove the permeate, feed and retentate port caps by twisting the caps counterclockwise. Remove the port O-rings.

NOTE O-rings are not reusable.

Insert sanitary gaskets and connect tubing to the feed, permeate and retentate ports, securing fittings with sanitary clamps.

Capsules supplied with AseptiQuik® Connectors:

Aseptically connect the capsule to the corresponding TFF system flowpath lines using genderless AseptiQuik® connectors. Refer to the [manufacturer's instructions](#).

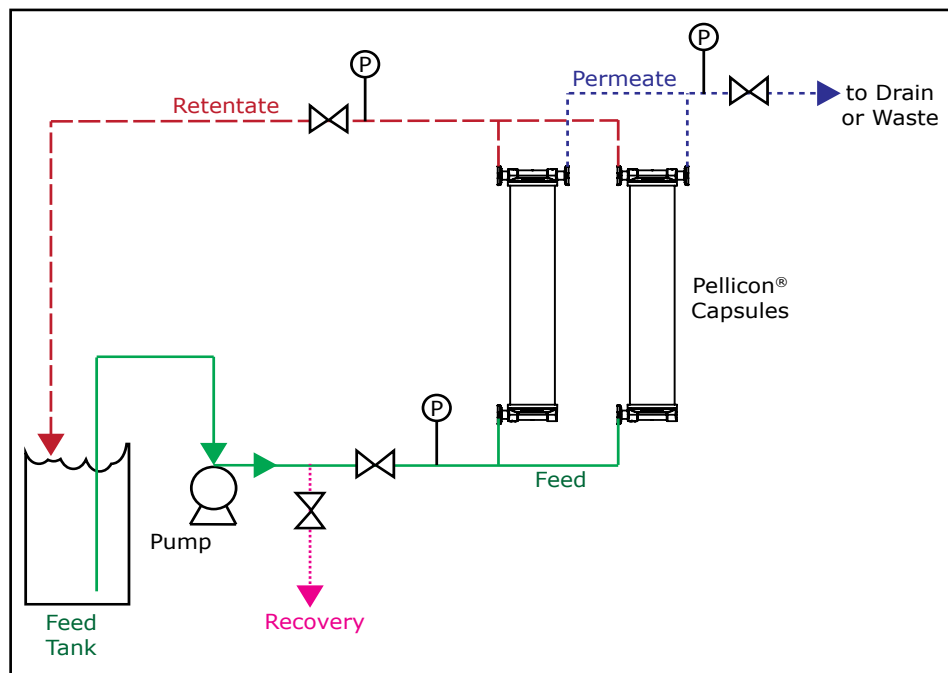

Batch TFF installation with multiple Pellicon® capsules

3. Install pressure transducers and pinch valves where required on the feed, retentate and permeate lines.
4. Connect the feed line to the feed pump.
Optional for ≥ 100 kDa cutoffs: Connect the permeate line to the permeate pump.
5. Install a recovery line and pinch valve after the feed pump and before the capsule feed port, if needed for product recovery.
6. Direct the permeate line to drain or to waste container.
7. Direct the retentate line to the feed tank.

Single-pass TFF Installation

Single-pass TFF installations allow the feed to pass through each filter once to generate permeate and concentrated retentate without recirculation.

Single-pass TFF installations use either one or multiple Pellicon® capsules. Multiple capsule installations require the capsules be assembled in series, with the total membrane area equally distributed in the serialized sections. For example, a process requiring a total of 0.3 m² of filter area would consist of three 0.1 m² capsules in series.

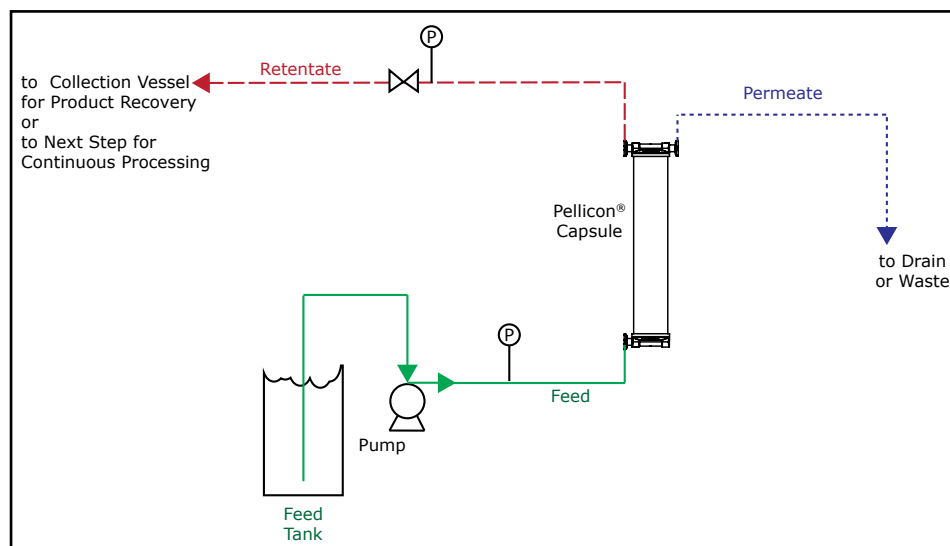

Single-pass TFF installation with one Pellicon® capsule

1. Install the Pellicon® capsule vertically with the permeate and retentate ports on top.
2. **Capsules supplied with port caps:** Remove the permeate, feed and retentate port caps by twisting the caps counterclockwise. Remove the port O-rings.

NOTE O-rings are not reusable.

Insert sanitary gaskets and connect tubing to the feed, permeate and retentate ports, securing fittings with sanitary clamps.

Capsules supplied with AseptiQuik® Connectors:

Aseptically connect the capsule to the corresponding TFF system flowpath lines using genderless AseptiQuik® connectors. Refer to the [manufacturer's instructions](#).

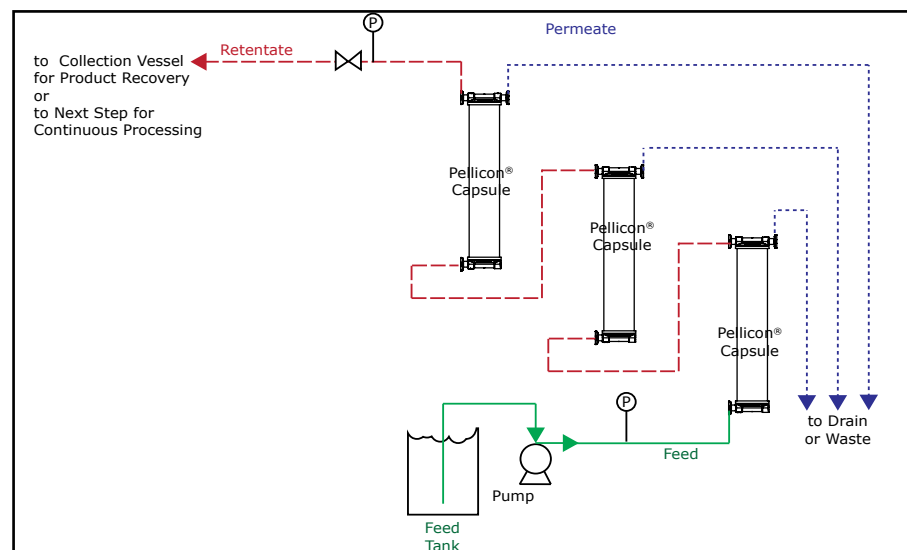

Single-pass TFF installation with multiple Pellicon® capsules

3. Install a pressure transducer on the feed tubing of the first capsule and connect the feed line to the pump.
4. Install a pressure transducer in the retentate tubing of the final capsule in the series then install a pinch valve downstream of the sensor.
5. Direct permeate lines to waste container or drain.
6. Direct retentate tubing of the final capsule to a collection vessel for product recovery or to the next step for continuous processing.

Manifold Installation

Pellicon® capsule manifold assemblies are standard units of multiple capsule devices (2 or 3) connected via single-use tubing assemblies that are terminated with AseptiQuik® G or L connectors. There are three manifold formats available as follows:

Format*	Description
G	Capsule Manifolds with AseptiQuik® G Connectors
L	Capsule Manifolds with AseptiQuik® L Connectors
E	Capsule Extender Manifolds with AseptiQuik® L Connectors on both ends

*Refer to the last digit of the catalog number.

Each unit is pre-assembled during manufacturing, mounted on a stainless-steel plate (3 and 4.5 m² only) for convenience during use, then individually packaged and gamma sterilized.

The product must not be lifted or carried by the tubing assemblies.

Provide adequate tubing length from the system to avoid stretching of the tubing that could lead to stress at connection points as well as prevent kinking of tubing that could restrict flow.

Installation of 1, 3 or 4.5 m² of Membrane Area

Pellicon® capsule manifold assemblies of 1, 3 and 4.5 m² of membrane area (manifold formats G) are shipped fully assembled with AseptiQuik® G connectors ready to connect to your TFF smart system. Refer to the [manufacturer's instructions](#) for details on making the aseptic connections.

The 1 m² manifold may be installed onto the Pellicon® capsule stand for vertical support during use.

Installation of 6, 7.5 or 9 m² of Membrane Area

Pellicon® capsule manifold formats E and L are individual assemblies of either 3 or 4.5 m² of membrane area. The E format is an extender assembly that enables increased membrane area installations when aseptically connected to an L assembly. To achieve installations of 6, 7.5, or 9 m² of membrane area, Pellicon® capsule manifold formats E and L are paired during installation as follows:

Membrane Area (m ²)	Catalog Number Required	
	E Manifold	L Manifold
6	PCC----30E	PCC----30L
7.5	PCC----30E	PCC----45L
9	PCC----45E	PCC----45L

NOTE Each E and L manifold unit must be ordered separately.

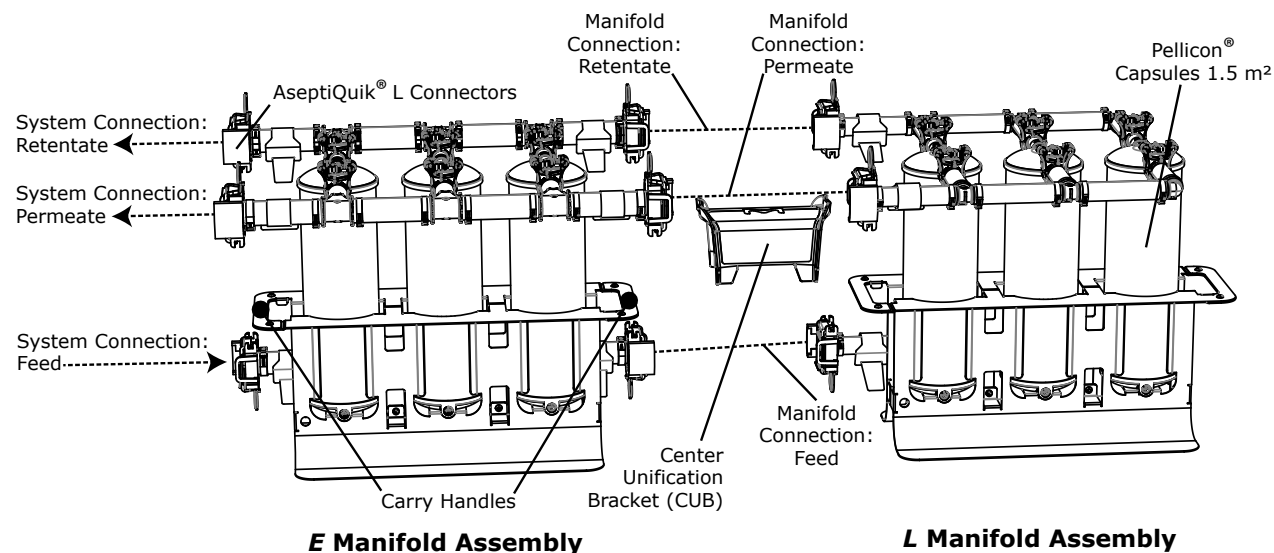

4.5 m² E manifold (left) and 4.5 m² L manifold (right), shown for a 9 m² installation

The following procedure requires various connections of AseptiQuik® L connectors. Refer to the [manufacturer's instructions](#) for details on making the aseptic connections.

1. To position E and L manifolds adjacent to the TFF smart system, lift each manifold individually by the handles on the plate of the filtration unit and place on a flat even surface near the system.

NOTE Do not lift or carry the product by the tubing assemblies.

2. Align the three (3) AseptiQuik® L connectors on one side of the E manifold labeled **To System** (refer to tag attached to each tubing line) to the corresponding feed, retentate, and permeate AseptiQuik® L connectors on the TFF system flow path.

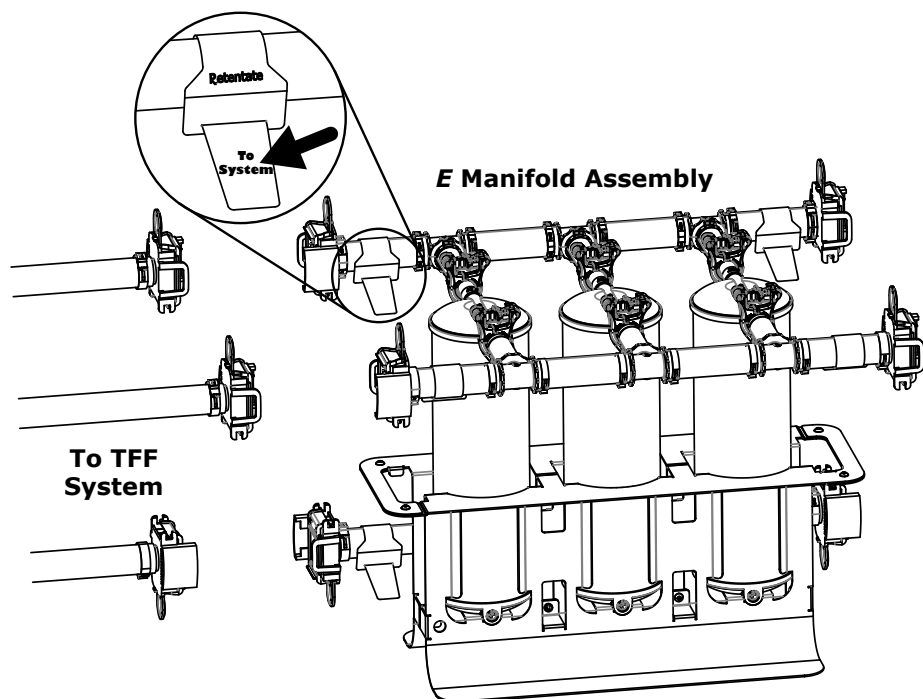

Alignment of AseptiQuik® L connectors between system and E manifold

3. Align the three (3) AseptiQuik® L connectors on the opposite side of the E manifold labeled **To Filter** to the three (3) AseptiQuik® L connectors of the L manifold. Ensure the tubeset tags opposite to each other match according to the intended flow path direction: **Feed to Feed, Retentate to Retentate, and Permeate to Permeate**.

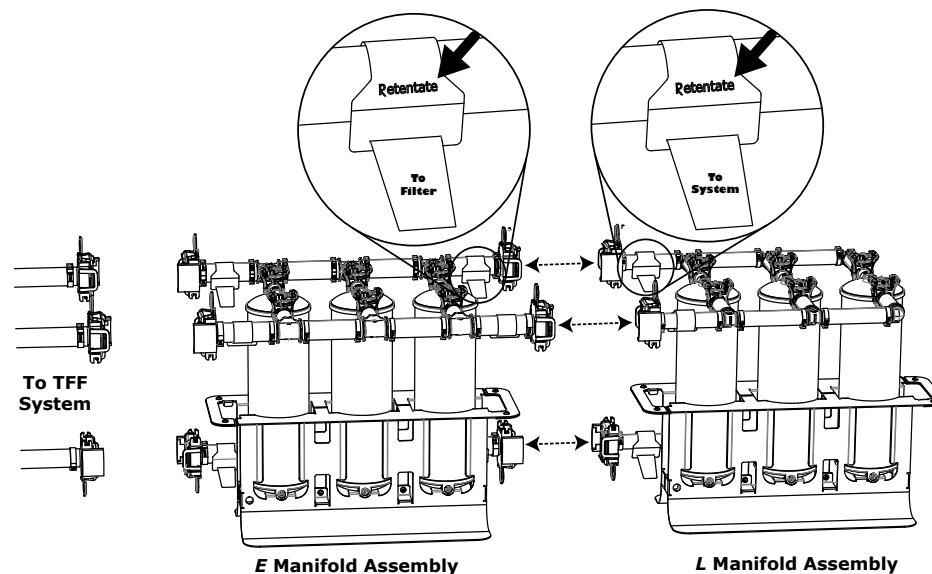

Alignment of AseptiQuik® L connectors between E and L manifolds

4. To pair the E manifold to the TFF smart system, push the feed side AseptiQuik® L connector on the E manifold to the TFF system feed side AseptiQuik® L connector (refer to the [manufacturer's instructions](#)). Then repeat for the retentate line, and finally the permeate line.

NOTE Do not pull the membrane tabs on the connectors at this step as the flow path installation is not complete.

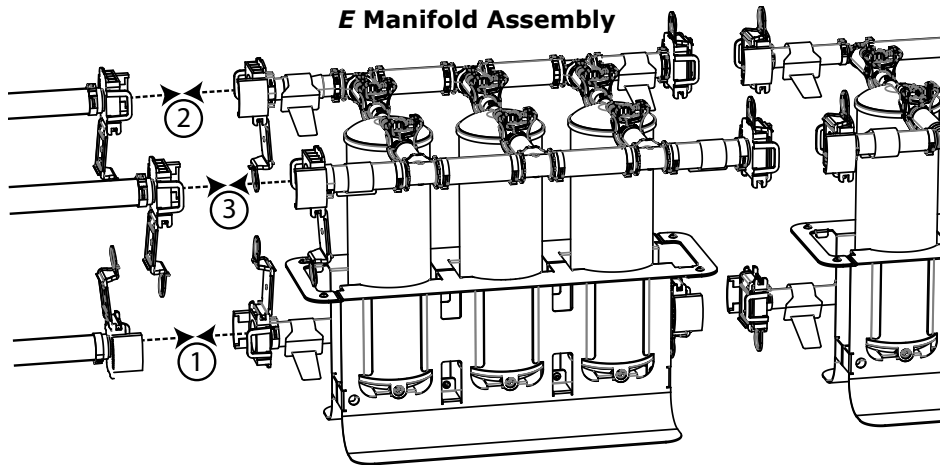

Pairing E manifold to TFF system

5. To pair the L manifold to the E manifold already coupled to the TFF system, push the feed side AseptiQuik® L connector (refer to the [manufacturer's instructions](#)) on the opposite side of the E manifold (opposite to the TFF system) to the L manifold feed side AseptiQuik® L connector. Then repeat for the retentate line, and finally the permeate line.

NOTE Do not pull the membrane tabs on the connectors at this step as the flow path installation is not complete.

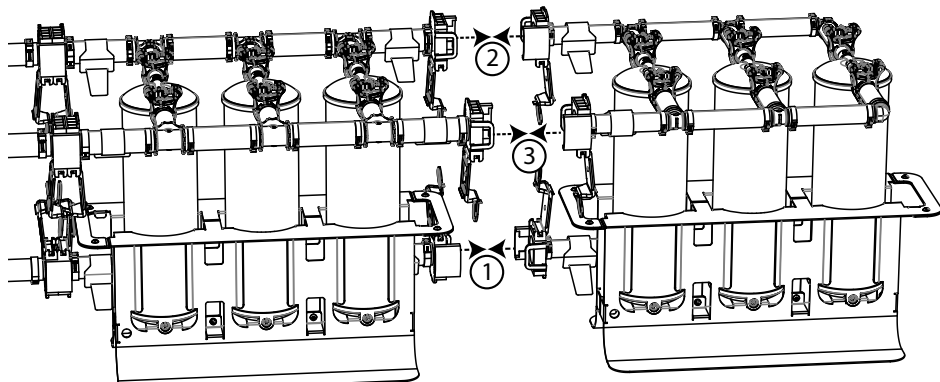

E Manifold Assembly

L Manifold Assembly

Pairing E and L manifolds

6. Insert the center unification bracket provided with the E manifold into the space on the inner handles of each manifold plate and push the center unification bracket down until it clicks into place, securely inter-locking the E and L manifolds. The center unification bracket should self-align in the features used to position it.

NOTE Both manifolds must be on the same flat surface to allow the center unification bracket to seat correctly and the four tabs on the bottom corners of the center unification bracket must lock under the plate inner handles, securely locking together the two manifold units.

Gently push the center unification bracket down:

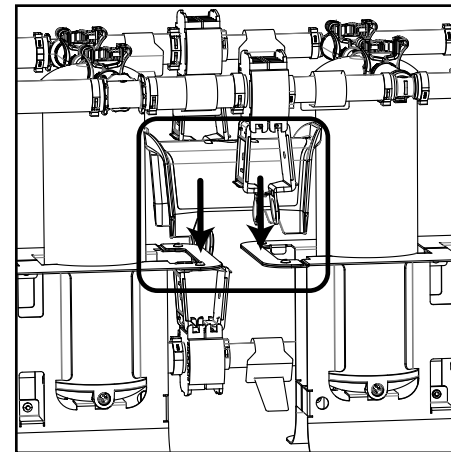

Center unification bracket clicks and secures manifolds:

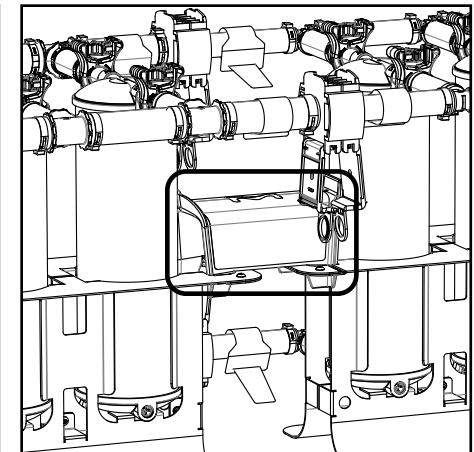

Inserting the center unification bracket

7. Once all connectors have been paired between the manifolds and to the TFF smart system and the center unification bracket is in place, pull the membrane tabs from the AseptiQuik® L connectors by following the [manufacturer's instructions](#) to complete the flow path through the filtration unit.

Integrity Testing

Optional integrity testing of the Pellicon® capsule may be performed on a water-wet membrane. Buffer or process solution should not be used for integrity testing as integrity test results can be significantly altered.

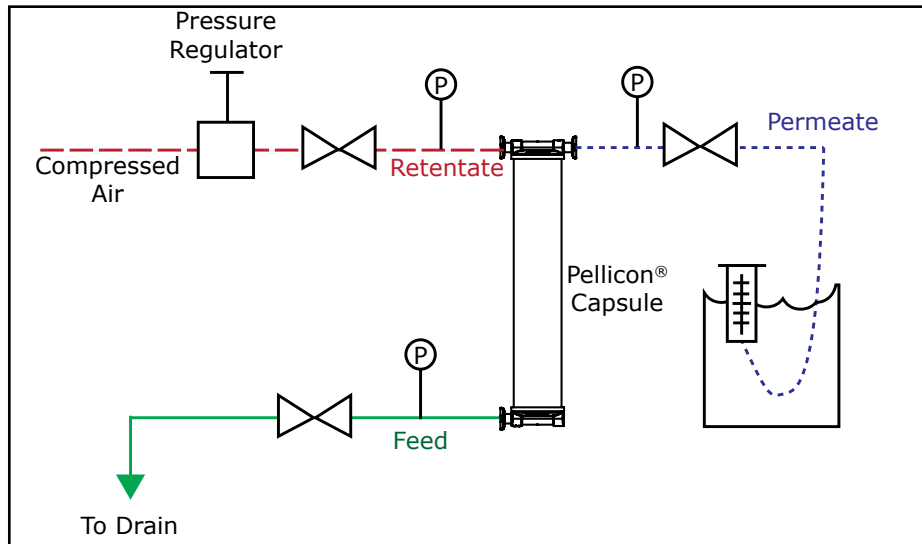

Integrity test set up

1. Drain the capsule.
2. Attach an airline with pressure regulator to the retentate line or directly to the retentate port of the capsule.
3. Open feed, retentate (as needed), and permeate valves.
4. Start air flow to the capsule; adjust air pressure to 3 to 5 psi using the pressure regulator.
5. Allow residual water from the device to be expelled from the feed and permeate lines for 1 to 3 minutes.
6. Close the feed valve.
7. Increase pressure to 30 psi and wait 3 to 5 minutes for air flow in the permeate line to stabilize.

Air Integrity Test Specifications Ultracel® Membrane

Membrane Cutoff	Air Flow Rate (cc/min) at 30 psig		
	0.1 m ² Capsule	0.5 m ² Capsule	1.5 m ² Capsule
30 kDa	≤ 14	≤ 70	≤ 210
100, 300 kDa	≤ 20	≤ 100	≤ 300

NOTE Do not exceed the recommended air pressure as this may result in excessively high air flow (a false failure). Rewet the membrane if this occurs.

8. Measure the air flow rate by using an air flow meter or by measuring the change in air volume in a submerged and inverted graduated cylinder as a function of time.

To measure by inverted graduated cylinder method, submerge graduated cylinder in water container, removing all air from the cylinder. Hold the cylinder inverted with the top of the cylinder approximately two inches below the surface of the water. Submerge the permeate line into the water container directly beneath the opening of the graduated cylinder. Record volume of air collected into the graduated cylinder and total time of air collection. Calculate the volume of air collected per minute.
9. Reduce air flow/pressure to the capsule and open feed valve to vent air pressure from the capsule.
10. Compare the measured air flow rate to the specified value on the Certificate of Quality or in the table above. If the measured air flow rate is equal or less than the maximum specified value, the capsule may be used for processing. If the measured air flow rate exceeds the specified value, refer to [Troubleshooting](#).

Conditioning Flush

Pellicon® capsules are wetted with reverse osmosis water, then gamma sterilized prior to shipment. Flushing removes the storage water present in the shipped product, and can be performed with either water for injection (WFI) or conditioning buffer. A flush volume of 20 L per m² of membrane area is recommended. For a streamlined process, a conditioning flush with processing buffer will simultaneously remove residuals from the filter and tubing as well as equilibrate the system to ensure its proper condition before product processing (recommended).

1. Fill the feed tank with an appropriate amount of clean water or buffer for the installed Pellicon® capsule membrane area and system size.
2. Direct the retentate and permeate lines to a waste container or to drain, with the permeate and retentate valves fully open.
3. Turn on the feed pump and pump fluid into the feed port of the Pellicon® capsule at 2 L/min/m².
4. Once the retentate flow has been established, set retentate pressure to 1-2 psi.

If using a permeate pump, slowly ramp up the permeate pump speed to 80% of the feed flow rate and adjust retentate pressure as needed.

5. Flush until the target volume (20 L/m²) has been pumped through the capsule. Leave the capsule and tubing full of water or buffer. Leave enough volume in the feed tank to submerge the retentate return line.
6. At the end of the flush, turn off the permeate pump (if applicable) and feed pump, then fully open the retentate valve.

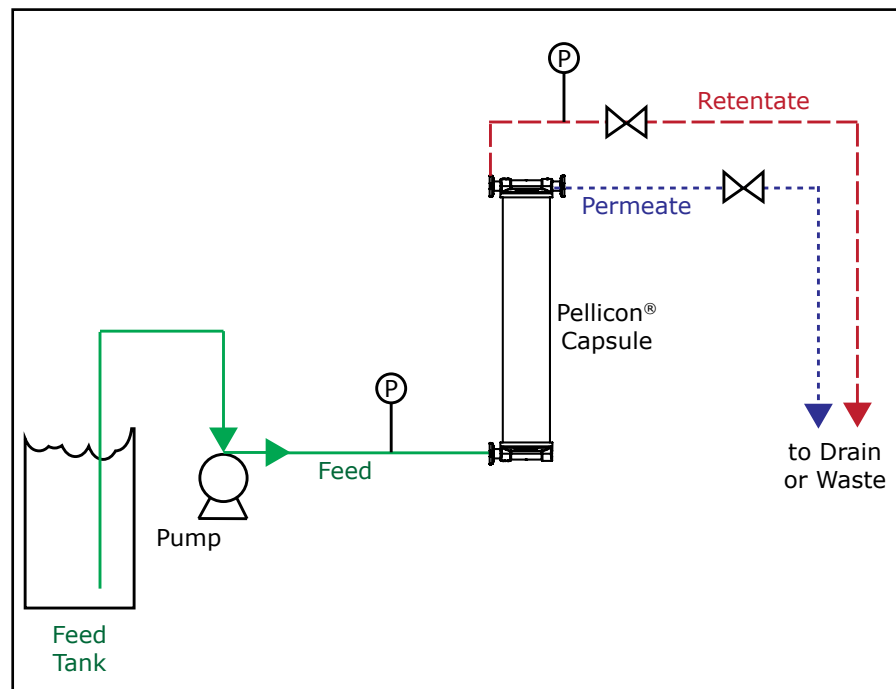

Conditioning set up

Product Processing

Typical TFF operation is designed to control transmembrane pressure (TMP) via the retentate valve, referred to as TMP control or one-pump system. For open membranes, e.g., Ultracel® 100 and 300 kDa, an alternative system operation may be used in which the permeate flux is controlled by a permeate pump, referred to as permeate control or two-pump system.

Membrane Cutoff	System Type
30, 100, 300 kDa	TMP control or one-pump
100, 300 kDa	Permeate control or two-pump

The following procedures describe both modes of TFF operation and are meant to serve as a guide. Procedures and conditions should be confirmed by the end user while using a feed stream and optimized conditions representative of their specific application.

The following instructions apply to batch processes where a recirculation loop is used. For single-pass operation, adjust the installation assembly as required.

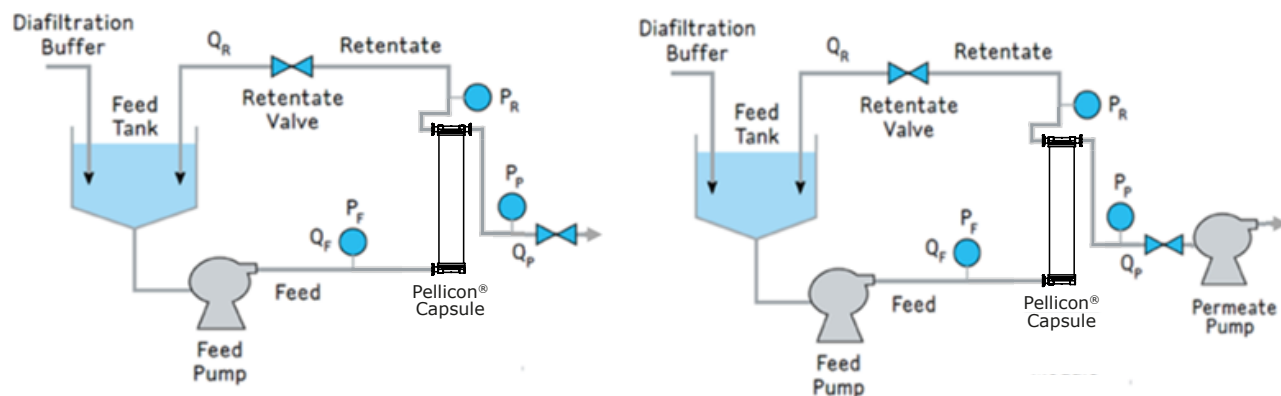

TMP control or one-pump setup (left) and permeate control or two-pump setup (right)

Concentration

1. After [Conditioning Flush](#), leave capsule and tubing full of processing buffer. Leave enough buffer in feed tank to submerge the retentate return line.
2. Direct the retentate line to the feed tank and the permeate lines to waste.
3. Add product to the feed tank.
4. Fully open the retentate valve and permeate line.
5. Turn the feed pump on and ramp up to target feed flow rate.
6. Set control conditions according to the system type to concentrate product:

TMP Control (one-pump) System:

Partially close the retentate valve to achieve the optimum TMP.

Permeate Control (two-pump) System:

Turn the permeate pump on and slowly adjust to achieve the target permeate flow rate.

Adjust retentate valve to achieve target retentate pressure, generally at low end of range. Maintain a positive permeate pressure (may require increasing the retentate pressure).

NOTE If TMP rises quickly at any point, reduce permeate flux to stabilize.

Typical Operating Conditions for a Batch Process*

Membrane Cutoff	Feed Flow Rate	Retentate Pressure
30 kDa	4 to 8 L/min/m ²	0.7 to 1.4 bar 10 to 20 psi
100, 300 kDa	4 to 6 L/min/m ²	0.14 to 0.7 bar 2 to 10 psi

*The optimum feed flow rate and TMP (for one-pump) or permeate flux (for two-pump) will depend on the solution being filtered and are determined experimentally.

- Record the feed and permeate flow rates; feed, retentate, and permeate pressures; and temperature throughout the concentration process.
- After reaching the target concentration, close the permeate line, fully open the retentate valve and turn off the feed pump.

Diafiltration

- Configure the system for diafiltration with the buffer, feed and retentate lines to the tank, the permeate line to drain or collection vessel and the retentate and permeate valves fully open.
- Set control conditions according to the system type described above (TMP Control or Permeate Control) to diafilter product.
- Adjust the buffer flow rate to be equivalent to the permeate flow rate to maintain constant volume in the feed tank.
- Diafilter the product with the required number of diavolumes based on the process specifications.

Diavolume (DV or N) = total buffer volume to permeate divided by the retentate volume to diafilter.
- After reaching the target diafiltration volume, close the permeate line, fully open the retentate valve and turn off the feed pump.

Recovery

There are various methods for product recovery. The following instructions give one example. Contact Technical Service for assistance with other recovery methods.

- Recirculate at 1 L/min/m² (feed flux) for 10 minutes with the retentate valve open and permeate line closed.
- Recover product from the feed tank by draining or by pumping out through the retentate line to the recovery vessel.
- Add at least one hold-up volume of buffer to feed tank then pump out system to recover additional product.

Waste Compliance

Disconnect the Pellicon® capsule and tubing from the system and discard according to local regulations.

Pellicon® Capsule Stand

Installation

The Pellicon® capsule stand accommodates up to two 0.1 m² capsules in parallel or three 0.1 m² capsules in series on one side and one 0.5 m² capsule or one 1 m² manifold on the opposite side. Install the capsules on the stand by pushing the capsules into the clamps.

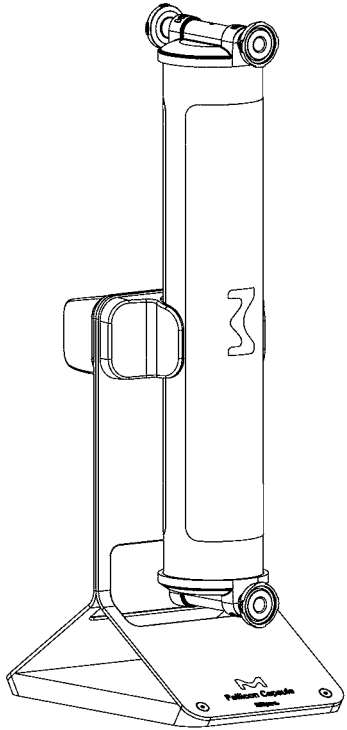

0.5 m² capsule installed on a Pellicon® capsule stand

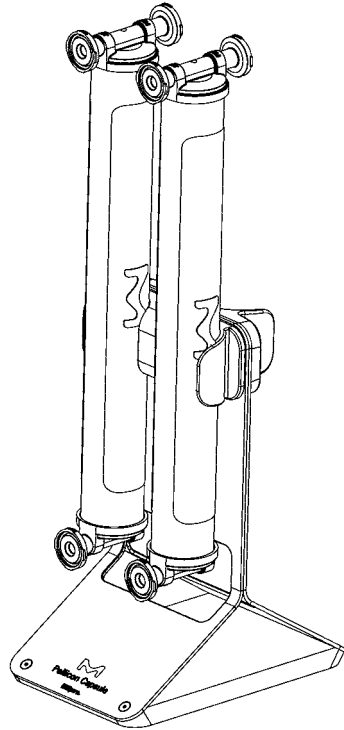

Two 0.1 m² capsules installed on a Pellicon® capsule stand

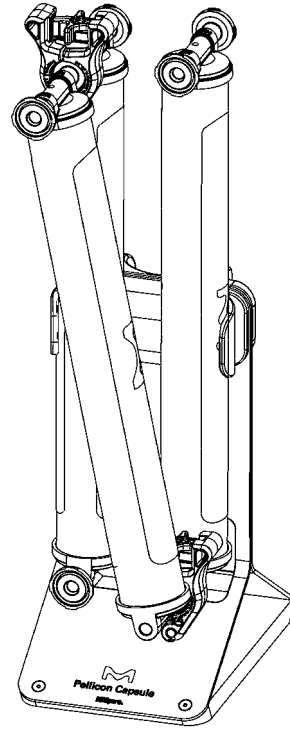

Three 0.1 m² capsules installed in series on a Pellicon® capsule stand

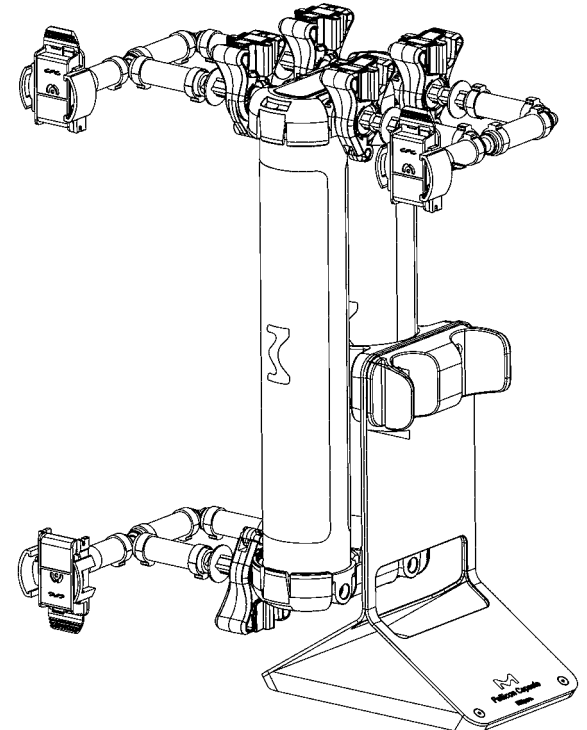

1 m² capsule manifold installed on a Pellicon® capsule stand

Troubleshooting

Problem	Possible Cause	Remedy
Tubing/fitting leaks	Tubing split or fitting damaged	Replace damaged part.
	Tubing not fully inserted into fitting	Cut end squarely and insert fully into fitting.
	The threads of NPT fitting not wrapped with PTFE tape	Tape with PTFE tape.
	Misaligned, defective, or missing seal	Inspect, re-seat, replace missing component.
	Loose clamp	Tighten clamp.
	Oversized clamp	Replace with smaller diameter clamp.
	AseptiQuik® G or L Connector halves not connected properly or misaligned.	Refer to the manufacturer's instructions .
Capsule housing leak	Damaged housing	Replace capsule.
Immediate complete pressure loss	Tubing or fitting leaks	See Remedies under Tubing/fitting leaks.
Foaming in system	Fitting leak allowing aspiration of air into system	See Remedies under Tubing/fitting leaks.
	Feed line sucking air	Ensure feed line is fixed below fluid/air interface.
	Vortex in feed container	Add a baffle to break vortex, reduce mixing speed, redirect return line, or increase volume in tank.
	Retentate splashing	Secure retentate line below fluid level.
	Pump cavitation	Check feed tubing to pump connection for obstruction; remove obstruction or replace damaged/collapsed tubing.

Problem	Possible Cause	Remedy
Low retention	Membrane damaged	Replace filter. Determine cause to avoid recurrence. Physical damage, such as exceeding permeate backpressure limits may cause damage to the membrane.
Integrity test failure	Areas of membrane incompletely wetted	Flush with water and retest. Ensure pump size meets flow requirement and achieves target retentate pressure.
	Membrane damaged	Replace filter. Determine cause to avoid recurrence. Physical damage, such as exceeding permeate backpressure limits may cause damage to the membrane.
	Filter element damaged	Replace filter. Determine cause to avoid recurrence. Do not exceed maximum operating conditions or solvent levels.
High pressure in capsule from protein processing	Foam in system	See remedy under Foaming in system. Let system sit to allow gas to coalesce and leave feed tank and capsule (pump out with retentate valve fully open).
	Plugging of filter	Try to remove with forward and reverse flushing. Determine cause to avoid recurrence. Cause may include inadequate pre-filtration of feed stock or generation of particles during process, e.g. from precipitation or shedding.

We provide information and advice to our customers on application technologies and regulatory matters to the best of our knowledge and ability, but without obligation or liability. Existing laws and regulations are to be observed in all cases by our customers. This also applies in respect to any rights of third parties. Our information and advice do not relieve our customers of their own responsibility for checking the suitability of our products for the envisaged purpose.

For more information and documentation please contact:
Merck KGaA, Darmstadt, Germany
Corporation with General Partners
Frankfurter Str. 250
64293 Darmstadt, Germany
Phone: + 49 6151-3599 300

For requests from USA and Canada
please contact:
MilliporeSigma
A subsidiary of Merck KGaA, Darmstadt, Germany
400 Wheeler Rd
Burlington, MA 01803
Phone: 1-800-645-5476

www.sigma-aldrich.com

Millipore, Pellicon and Ultracel are trademarks of Merck KGaA, Darmstadt, Germany or its affiliates. All other trademarks are the property of their respective owners. Detailed information on trademarks is available via publicly accessible resources.
© 2022 Merck KGaA, Darmstadt, Germany and/or its affiliates. All Rights Reserved.

MS_UG1549EN Rev 4 10/2022

The logo for MilliporeSigma, featuring the word "MILLIPORE" in a bold, blue, sans-serif font above the word "SIGMA" in a similar bold, blue, sans-serif font. The letters are closely spaced and have a slight shadow effect.